

**Instructions for Use**  
**Reprocessed Achieve Advance Mapping**  
**Diagnostic Electrophysiology Catheter**

**Reprocessed Device for Single Use**

**Caution: Federal (USA) law restricts this device to sale by or on the order of a physician.**

**DEVICE DESCRIPTION**

The Reprocessed Achieve Advance Mapping Diagnostic Electrophysiology Catheter is an intra-cardiac electrophysiology (EP) recording catheter and can be used for cardiac stimulation during electrophysiology studies. The distal mapping section of the reprocessed mapping catheter is a circular loop with eight or ten evenly spaced electrodes to map electrical conduction between the left atrium and the pulmonary veins.

The reprocessed mapping catheter is compatible for use with, and may be used to support and position, all catheters in the Medtronic Arctic Front CryoAblation Catheter family. Refer to the applicable Medtronic Arctic Front Technical Manual for additional instructions for use.

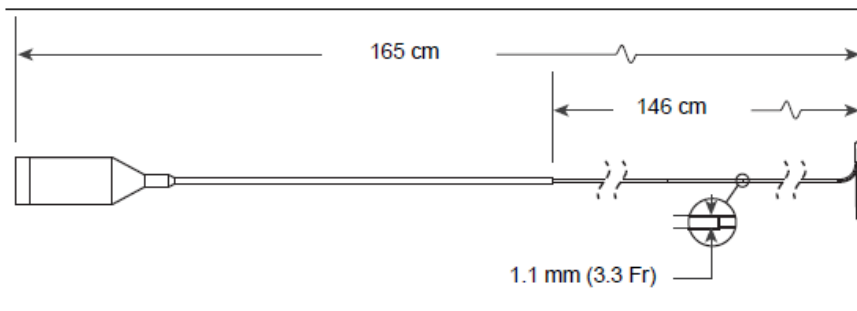

Figure 1. Reprocessed Achieve Advance Mapping Diagnostic Electrophysiology Catheter dimensions

The distal mapping section of the reprocessed mapping catheter is a circular loop with eight or ten evenly spaced electrodes to map electrical conduction between the left atrium and the pulmonary veins. Please refer to Figure 2 below.

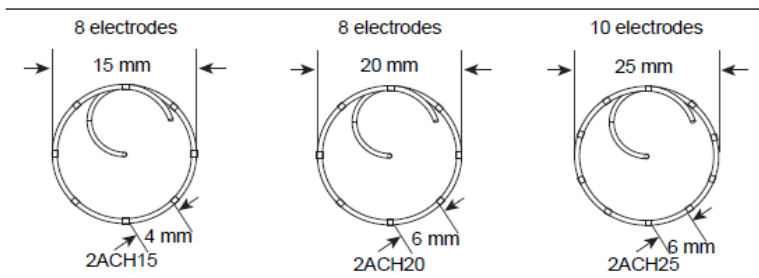

Figure 2. Reprocessed Achieve Advance Mapping Diagnostic Electrophysiology Catheter loop

### **Instructions for Use: Reprocessed Achieve Advance Mapping Diagnostic Electrophysiology Catheter**

The reprocessed mapping catheter should only be used with the Medtronic catheter connecting cable (Model 2ACHC), which interfaces with standard electrophysiology recording equipment. For cable instructions, see the Medtronic 2ACHC catheter connecting cable instructions for use.

#### **INDICATIONS FOR USE**

The Reprocessed Achieve Advance Mapping Diagnostic Electrophysiology Catheter is indicated for multiple electrode electrophysiological mapping of the cardiac structures of the heart, i.e. recording or stimulation only. The catheter is designed to obtain electrograms in the atrial regions of the heart.

#### **CONTRAINDICATIONS FOR USE**

- The catheter is contraindicated for use as an ablation device.
- The catheter is contraindicated for use with transeptal sheaths featuring side holes larger than 1.1 mm (0.043 in) in diameter.
- The catheter is contraindicated for use via retrograde approach.
- Electrophysiology studies are contraindicated when the patient's underlying cardiac disease makes it likely that induced arrhythmias will be extremely difficult to terminate and carry a high risk of death, as in the following conditions:
  - An active systemic infection
  - Left atrial thrombus
  - Pulmonary vein stents
  - Prosthetic heart valve (tissue or mechanical)
  - Myxoma
  - Interatrial baffle or patch
  - Conditions where the manipulation of the catheter within the heart would be unsafe
  - Acute myocardial infarction

#### **WARNINGS**

- This equipment should be used by or under the supervision of physicians trained in cardiac catheterization procedures.
- Cardiac catheterization procedures present the potential for significant x-ray and fluoroscopic exposure, which can result in acute radiation injury as well as increased risk for somatic and genetic effects, to both patients and laboratory staff due to the x-ray beam intensity and duration of the fluoroscopic imaging. Cardiac catheterization should only be performed after adequate attention has been given to potential radiation exposure associated with the procedure, and steps taken to minimize this exposure. The long-term effects of protracted fluoroscopy have not been established.
- Do not connect the reprocessed mapping catheter to a radiofrequency (RF) generator or use it to deliver RF energy. Doing this may cause catheter malfunction or patient harm.
- Use of fluoroscopy during catheter manipulation and placement is strongly advised. Manipulating the catheter without fluoroscopy may result in damage to cardiac and vascular structures.
- Avoid positioning the catheter around the chordae tendineae as this increases the likelihood of catheter entrapment within the heart, which may necessitate surgical intervention or repair of injured tissues.
- Do not pass the catheter through a prosthetic heart valve (mechanical or tissue). The catheter may become trapped in the valve, damaging the valve and causing valvular insufficiency or premature failure of the prosthetic valve.
- Introducing any catheter into the circulatory system entails the risk of air or gas embolism, which can occlude vessels and lead to tissue infarction with serious consequences. Always advance and withdraw components slowly to minimize the vacuum created and therefore minimize the risk of air embolism.
- Catheter procedures may mechanically induce arrhythmias.
- Use only isolated equipment (IEC 60601-1 Type CF equipment, or equivalent) with the reprocessed mapping catheter or patient injury or death may occur. Do not allow leakage current from any connected devices to the patient to exceed 10  $\mu$ A under any circumstances.

### **Instructions for Use: Reprocessed Achieve Advance Mapping Diagnostic Electrophysiology Catheter**

- Do not allow the patient to contact grounded equipment that might produce electrical current leakage during ablation or DCCV (Direct Current CardioVersion). Electrical current leakage may induce arrhythmias that may result in the patient's death.
- Do not allow any exposed metal portion of the shaft to contact grounded equipment. Electrical current leakage may induce arrhythmias that may result in the patient's death.
- Remove the catheter from the patient prior to cardioversion/defibrillation. Failure to do so may result in injury or death to patient and user, and may damage the device. Do not touch the patient or the catheter during cardioversion/defibrillation. Direct contact with the patient or the catheter during cardioversion/defibrillation may result in shock.
- Use the reprocessed mapping catheter only with the Medtronic catheter connecting cable model 2ACHC, and a compatible mating device with a minimum internal diameter of 1.1 mm (0.043 in) and standard 9 Fr hemostasis valve. The mapping catheter is not recommended for use with RF ablation catheters. The Reprocessed Achieve catheter is compatible for use with all catheters in the Medtronic Arctic Front family of cardiac cryoablation catheters.
- Administer appropriate levels of peri-procedural anticoagulation therapy for patients undergoing left-sided and transseptal cardiac procedures. As preclinical animal testing with this device showed significant thrombus formation in the absence of anticoagulation, administer anticoagulation therapy during and post-procedure according to the institution's standards.
- Always rotate the mapping catheter in a clockwise direction to prevent tissue damage.
- Tactile feedback of reprocessed device may vary during use.

### **PRECAUTIONS**

- Do not attempt to operate the catheter prior to completely reading and understanding these directions for use.
- Personnel handling the electrophysiology catheter should wear gloves.
- Avoid catheter entanglement with other catheters, devices, or wires. Such entanglement may necessitate surgical intervention.
- Do not use the catheter if it is kinked, damaged, or cannot be straightened. If the catheter becomes kinked or damaged while in the patient, remove it and use a new catheter.
- Use extreme care when manipulating the catheter. Lack of careful attention can result in injury such as perforation or tamponade.
- Excessive bending or kinking of the catheter may cause damage to the catheter and compromise the structural integrity of the device and increase the risk of catheter failure. Do not at any time preshape or bend the catheter shaft or distal (loop) segment. Manual prebending of the distal loop can damage the catheter and may cause patient injury.
- Standard grounding procedures should be followed if electrosurgical instruments are used.
- Careful catheter manipulation must be performed in order to avoid cardiac damage, perforation, or tamponade. Catheter advancement and placement should be done under fluoroscopic guidance. Do not use excessive force to advance or withdraw the catheter, especially if resistance is encountered.
- Cardiac catheterization procedures should be performed only in a fully equipped electrophysiology laboratory.
- The reprocessed mapping catheter must always be used with equipment that complies with international safety standards.
- Do not immerse the electrical connectors in fluids or solvents. If these components get wet, electrical performance may be compromised. Do not expose the catheter or cable to organic solvents such as alcohol.
- This catheter has not been evaluate for safety and compatibility in the magnetic resonance (MR) environment. The safety of the catheter is unknown (such as heating, migration, or image artifacts). Scanning a patient during the use of this device may result in patient injury.

### **ADVERSE REACTIONS**

Potential adverse events associated with cardiac catheter procedures include, but are not limited to the following conditions:

### **Instructions for Use: Reprocessed Achieve Advance Mapping Diagnostic Electrophysiology Catheter**

- Access site vessel occlusion,
- Allergic reaction to x-ray contrast media,
- Arrhythmias,
- Proarrhythmia,
- Arteriovenous fistula,
- Bleeding related to anticoagulation,
- Bradycardia,
- Cardiac arrest
- Cardiac perforation of the heart or other organs during transeptal puncture or other procedures,
- Cardiac tamponade,
- Cardiac thromboembolism,
- Cerebrovascular accident (CVA) or transient ischemic attack (TIA),
- Chest discomfort,
- Chronic cough,
- Coronary artery spasm
- Death,
- Entrapment
- Fever,
- Heart failure,
- Hematoma,
- Hemoptysis,
- High creatinine phosphokinase or troponin level,
- Hypotension,
- Infections,
- Mitral valve trauma,
- Myocardial infarction or ischemia,
- Obstruction, perforation, damage, or spasm of the vascular system including the coronary circulation system,
- Pericarditis or endocarditis,
- Pleural or pericardial effusion,
- Pneumonia,
- Pulmonary embolism,
- Pulmonary infiltrates,
- Pulmonary vein narrowing or stenosis,
- Pseudoaneurysm in groin,
- Radiation injury or damage and late malignancy,
- Respiratory depression,
- Retroperitoneal bleed,
- Thrombotic or embolic events,
- Tissue infarction (such as myocardial infarction or renal infarction)
- Valvular insufficiency or damage and Vasovagal reaction.















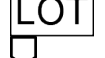

### **DIRECTIONS**

- The package label is detachable and may be affixed to the medical record of the patient.
- Inspect the catheter and packaging before opening. The contents of the package are sterile unless the package is opened or damaged. If the catheter is damaged or if the package is compromised, do not use the catheter. Return the catheter to Innovative Health. **Do not attempt to resterilize.**
- Using proper sterile technique, remove the catheter from its package and place it in a sterile work area.
- Inspect the electrodes and catheter carefully for integrity, continuity of leads and overall condition.
- Follow standard practice for vessel and transeptal puncture, guidewire insertion, guiding sheath use, and aspiration procedures.
- Connect the catheter connecting cable to the mapping catheter. Ensure ECG connections on the cable are connected to the EP recording system.

**Instructions for Use: Reprocessed Achieve Advance Mapping Diagnostic Electrophysiology Catheter**

- Note: when connecting the Medtronic catheter connecting cable (2ACHC) to the EP recording system, pins 9 and 10 will not be used on the 8-electrode catheters (2ACH15 and 2ACH20).
- Use of the Medtronic 8-pin cable (990066) will result in a loss of functionality, if used with the 25 mm reprocessed Achieve Advance mapping catheter (2ACH25).
- Loosen the introducer/torquer before sliding it forward to capture the distal loop.
- Slide the introducer/torquer over the distal loop. Do not tighten the introducer/torquer before sliding it over the distal section of the mapping catheter.
  - Note: Over-tightening the torquer results in the inability to capture the loop.
- Insert the reprocessed mapping catheter through a compatible mating device with a minimum internal diameter of 1.1 mm (0.043 in) until the catheter loop exits the distal tip of the compatible device.
- Avoid torquing the reprocessed mapping catheter during delivery through the compatible device.
- Use fluoroscopic guidance during the use of this catheter.
- Advance the reprocessed mapping catheter into the desired position.
- Ensure that any exposed metal portion of the shaft does not contact grounded equipment.
- Mishandling of the reprocessed mapping catheter could result in deformation of the distal loop.
- Always rotate the connector in a clockwise direction to position the mapping loop in the appropriate location to avoid tissue injury.
- If catheter rotation is required to facilitate with position of the mapping loop in the desired location, first tighten the introducer/torquer before rotating the catheter.

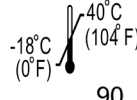
**Explanation of Symbols**

	Federal Law in the USA restricts this device to sale by or on the order of a physician
	Sterilized by Ethylene Oxide Gas
	Catalog Number
	Serial Number
	Lot Number
	Use by Date
	Do Not Reuse
	Do Not Resterilize
	Consult Instructions for Use
	Keep Product Dry
	Keep Away from heat and sunlight
	Manufacturer
	Do Not Use if Package is Damaged
	Non-pyrogenic
	Temperature limit
	Humidity limitation

As the reprocessor, Innovative Health is solely responsible for this device. All Original Manufacturer (OM) information is provided for device identification and may contain trademarks from third parties that do not sponsor this device.

**Sterilization:** This product and its packaging have been sterilized with Ethylene Oxide (EO) gas. Even though the product is processed in compliance with all applicable laws and regulations relating to EO exposure, Proposition 65, a State of California voter initiative, requires the following notice:

**Warning:** This product and its packaging have been sterilized with EO. The packaging may expose you to EO, a chemical known to the State of California to cause cancer or birth defects or other reproductive harm.

Achieve Advance is a registered trademark of Medtronic, Inc.

Please refer to [www.innovative-health.com](http://www.innovative-health.com) for product warranty.