



## **Instructions for Use Reprocessed Polaris X™ Steerable Diagnostic EP Catheter**

### ***Reprocessed Device for Single Use***

**Caution: Federal (USA) law restricts this device to sale by or on the order of a physician.**

#### **DEVICE DESCRIPTION**

The Reprocessed Polaris X Steerable Diagnostic EP Catheters are designed for use in intracardiac pacing and recording only. The catheters have been designed to carry electrical signals for the purpose of endocardial stimulation (pacing) or recording. The catheter is a uni-directional steerable catheter. The curve is actuated by means of a patented thumb-slide (see Figure 1).

#### **INDICATIONS FOR USE**

The Reprocessed Polaris X Steerable Diagnostic EP Catheter is intended for temporary use in electrophysiology studies for intracardiac stimulation (pacing) and/or recording of electrical potentials.

#### **CONTRAINDICATIONS FOR USE**

- Caution should be exercised, in the use of this or any other catheter, in patients with prosthetic valves.
- Patients with recurrent sepsis or with hypercoagulable state should not be considered candidates for transvascular catheters, since the catheter could serve as a focal point for septic or blood thrombus formation.

#### **WARNINGS**

- The device(s) should be used by physicians thoroughly trained in the techniques of invasive cardiology and in the specific approach to be used.
- Carefully read all instructions prior to use. Observe all contraindications, warnings and precautions noted in these instructions. Failure to do so may result in patient complications. It is the responsibility of the physician to determine, assess and communicate to each patient all foreseeable risks of the procedure.
- Care must be taken that any equipment used in connection with the BSC Catheters be type CF, be defibrillation proof, meet IEC 60601-1 electrical safety requirements, and comply with local regulatory requirements for the specified intended use.
- No modification of equipment is allowed.
- The use of catheters or cables with unprotected male pin connectors presents a risk of electrical hazard. Inadvertent attachment of pin connectors to power supply sockets of connectors could result in electrocution of the patient or operator.
- Diagnostic electrophysiology involves x-ray exposure that present the potential risk for somatic and genetic effects, to both patients and laboratory staff due to the x-ray beam and intensity and duration of the fluoroscopic imaging. Steps should be taken to minimize this exposure as much as possible.

### **Instructions for Use: Reprocessed Polaris X Steerable Diagnostic EP Catheter**

- Careful catheter manipulation must be performed to avoid cardiac damage, perforation, or tamponade. Catheter advancement should be performed under fluoroscopic guidance. Do not use excessive force to advance or withdraw the catheter when resistance is encountered.
- This catheter is not indicated for use in Cardiac Ablation or Coronary Artery Mapping.
- Tactile feedback of reprocessed devices may vary during use.

### **PRECAUTIONS**

- Excessive bending or kinking of the catheter of the catheter shaft may damage internal wires. Manual prebending of the distal curve can damage the steering mechanism and/or electrical wires, and may cause patient injury.
- Before using, inspect for physical damage, including electrical insulation on the cables and the catheter shaft. Replace damaged equipment.

### **ADVERSE REACTIONS**

The following potential risks or discomforts may be associated with diagnostic BSC procedures. The frequency and severity of these adverse events can vary, and may necessitate additional medical intervention, including surgery.

- Allergic reaction
- Arrhythmias
- Cardiac or respiratory arrest
- Cardiac valve damage
- Catheter entrapment/entanglement
- Chest pain
- Damage to vessel intima or cardiac structures
- Death
- Embolus, air embolus
- Hematoma/ecchymosis
- Hemorrhage
- Hypotension
- Infection
- Myocardial infarction
- Perforation
- Pericardial effusion
- Pericarditis/pleuritis
- Pneumothorax
- Pseudoaneurysm
- Pulmonary edema
- Sinus or AV node injury
- Stroke
- Tamponade
- Thrombosis
- Vasovagal reaction
- X-ray exposure

### **DIRECTIONS**

- The package label is detachable and may be affixed to the medical record of the patient.
- Patient should be connected to an ECG recording system prior to commencing the procedure in order to permit arrhythmia monitoring.
- Inspect the catheter and packaging before opening. The contents of the package are sterile unless the package is opened or damaged. If the package is opened or damaged, or if the package was opened and the catheter unused, do not use the catheter. Return the catheter to Innovative Health for reprocessing. **Do not attempt to resterilize.**
- Using proper sterile technique, remove the catheter from its package and place it in a sterile work area.
- Create a vascular access by either cut down or percutaneous technique. The catheter may be used from the femoral, brachial, subclavian or jugular access sites through a sheath/dilator (6F (2.00 mm) or 7F (2.33 mm) dilator are to be used with the catheter).
- Continue to advance the catheter under fluoroscopic guidance to the desired intracardiac position.
- The tip can be deflected to allow for curve changes instantly by using the thumb slide mechanism. By pushing the thumb slide down, the curve becomes tighter. By pushing the thumb slide up, the curve straightens (Figure 1).
- For intracardiac recordings, connect the appropriate quick connect or lead tip pins of the connector to the appropriate quick connector lead tip pins of the connector to the appropriate electronic equipment and perform the study.
  - Note: Closer spaced electrodes may enhance localization of aberrant path ways.

### **Instructions for Use: Reprocessed Polaris X Steerable Diagnostic EP Catheter**

- For pacing, connect the distal catheter terminal to the negative terminal of an external pulse simulator and any proximal electrode to the positive terminal. The standard for pacing stimuli is set twice the diagnostic threshold with a duration of 1.5 to 2 msec. If the pacing threshold is greater than 1 to 2 mA, repositioning of the catheter should be considered.

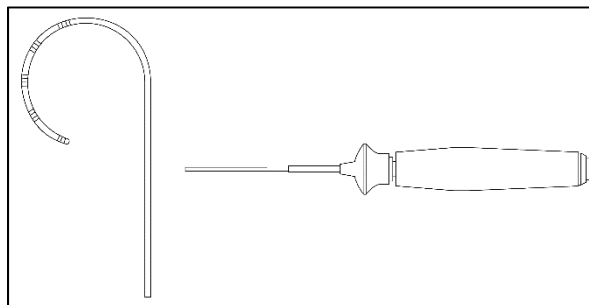

**Figure 1:** Polaris X Catheter

### **CATHETER REMOVAL**

- Prior to removing the catheter, ensure that the distal end of the catheter is straightened completely.
- Withdraw the catheter from the vessel.
- Remove the introducer sheath, then follow standard practice for management of insertion site.
- Place used catheters in the appropriate collection container.









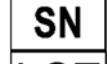

### **EQUIPMENT REQUIRED**

Intracardiac electrophysiology procedures should be performed in a specialized clinical setting, equipped with a fluoroscopy unit, radiographic table, physiologic recorder, emergency equipment and instrumentation for gaining vascular access. Ancillary materials required to perform EP studies include:

- 2.0mm Sheath w/dilator or 2.3 mm Sheath w/dilator
- ECG Recording System
- Pacing Stimulator

**Instructions for Use: Reprocessed Polaris X Steerable Diagnostic EP Catheter**

**Explanation of Symbols**

	Federal Law in the USA restricts this device to sale by or on the order of a physician
	Sterilized by Ethylene Oxide Gas
	Catalog Number
	Serial Number
	Lot Number
	Use by Date
	Do Not Reuse
	Do Not Resterilize
	Consult Instructions for Use
	Do Not Use if Package is Damaged
	Non-pyrogenic

As the reprocessor, Innovative Health is solely responsible for this device. All Original Manufacturer (OM) information is provided for device identification and may contain trademarks from third parties that do not sponsor this device.

**Sterilization:** This product and its packaging have been packaging have been sterilized with ethylene oxide gas (EO). Even though the product is processed in compliance with all applicable laws and regulations relating to EO exposure, Proposition 65, a State of California voter initiative, requires the following notice:

**Warning:** This product and its packaging have been sterilized with ethylene oxide. The packaging may expose you to ethylene oxide, a chemical known to the State of California to cause cancer or birth defects or other reproductive harm.

Polaris X is a trademark of Boston Scientific Corporation.

Please refer to [www.innovative-health.com](http://www.innovative-health.com) for product warranty.